

변경 사항			
기호	변경 내용	날짜	수정 승인

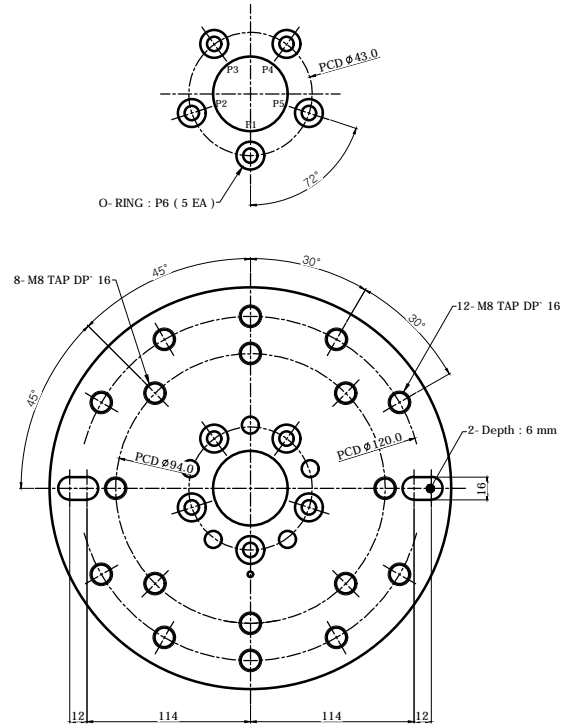

" C-Axis Spindle Dimensions ( 2 : 1 ) "

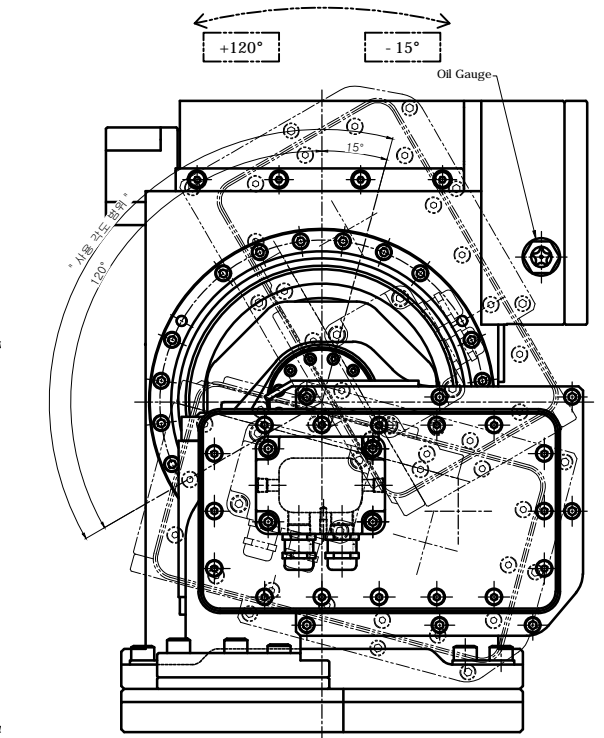
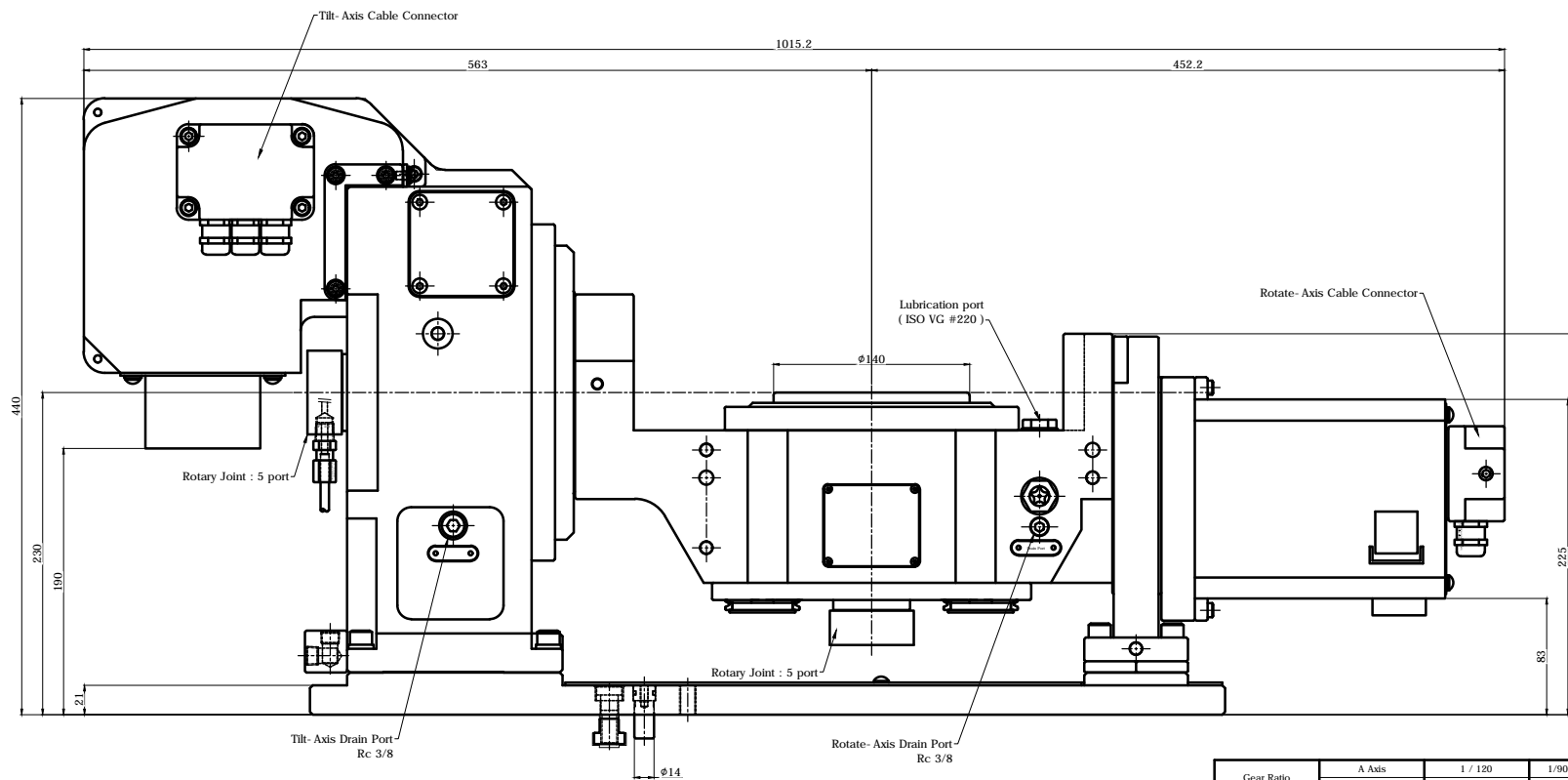
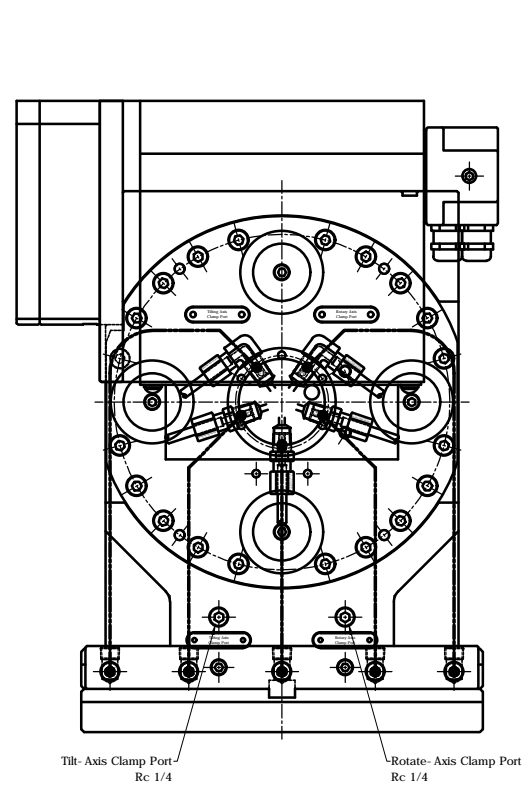
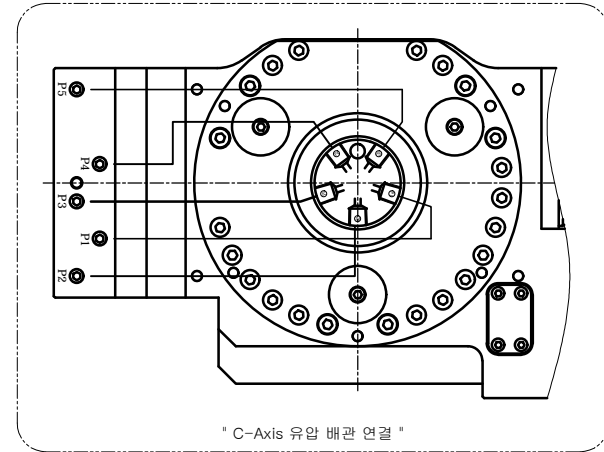
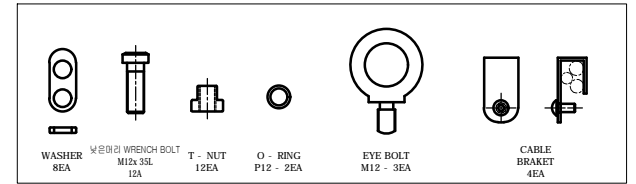
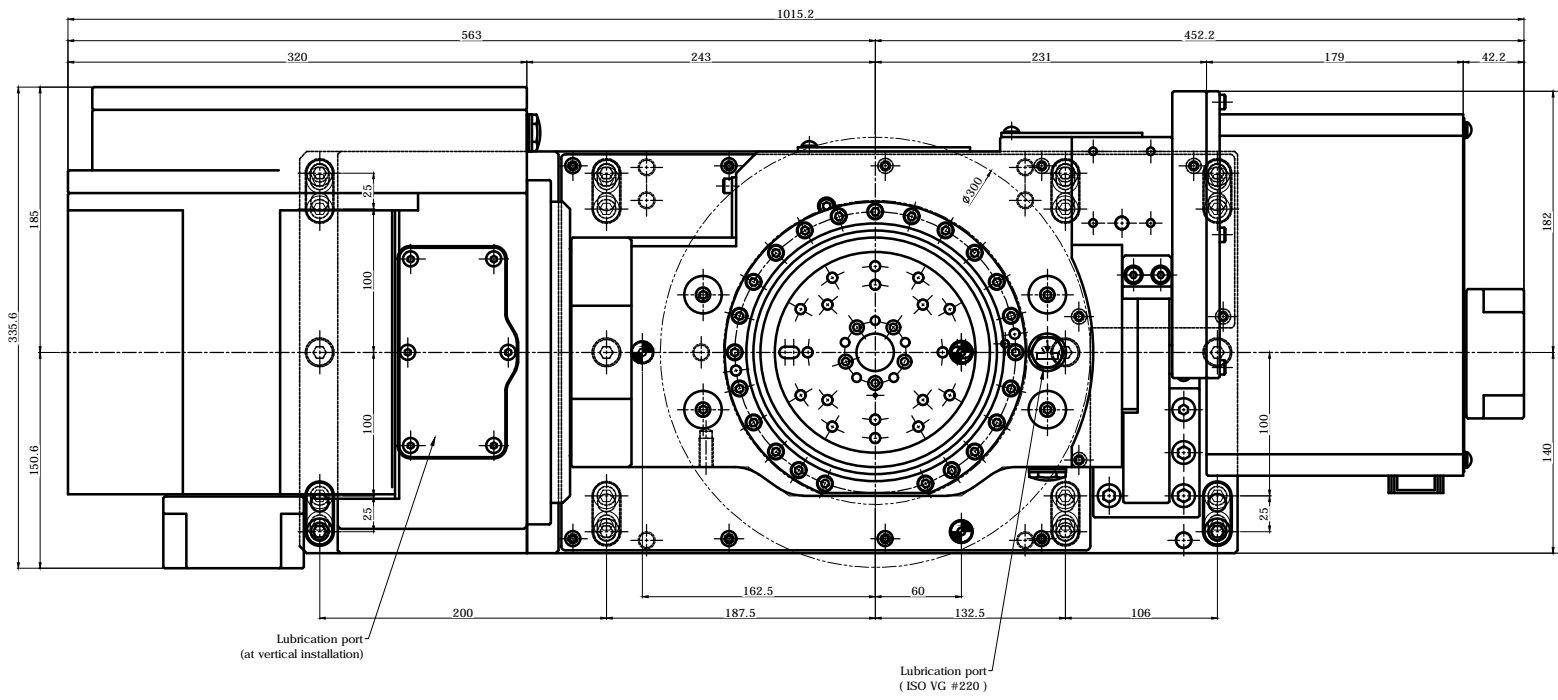

Gear Ratio	A Axis	1 / 120	1/90, 1.3333
	C Axis	1 / 60	-
MAX. Speed	A Axis	25 min <sup>-1</sup>	Servo Motor
	C Axis	50 min <sup>-1</sup>	3000min <sup>-1</sup>
Indexing Accuracy	A Axis	40 sec	-
	C Axis	20 sec	-
Clamp method	HYD.	Max. 25 bar	-
	A Axis	1000N.m	-
Clamp Torque	A Axis	600 N.m	-
	C Axis	800 N.m	-
Weight		250 kg	-

TITLE	Tilting NC Rotary Table	PART NAME	외 형 도
DRG. NO.	TMA200FF-V1.0-S01-00	USER	
CODE NO.		DEPARTMENT	Research & Development
		DATE	2019. 04. 10
SCALE	1 : 1	Approved	Checked
		Designed	

